

## Continuous Wavelet Transform (CWT) based Analysis of Very Fast Transient over Voltages of 132 KV Power Transformer

K.Prakasam<sup>1</sup>, D.Prabhavathi<sup>2</sup>, Dr.M.Suryakalavathi<sup>3</sup>,  
Dr.B.Ravindranath Reddy<sup>4</sup>

<sup>1</sup>Department of Electrical and Electronics Engineering, Sri Sivani College of Engineering, srikakulam, A.P, INDIA.

<sup>2</sup>Department of Electrical and Electronics Engineering, Sri Sivani College of Engineering, Srikakulam, A.P, INDIA.

<sup>3</sup>Department of Electrical and Electronics Engineering, JNTUH, Hyderabad, INDIA.

<sup>4</sup>Department of Electrical and Electronics Engineering, JNTUH, Hyderabad, INDIA.

### ABSTRACT

*This paper results the most accurate results of Very Fast Transient over Voltages of 132 KV transformer caused by the switching operation. A 132KV transformer is designed using MATLAB simulink, the VFTOs generated by the switching operations have been analyzed and are presented. The VFTOs generated due to Disconnecter switching operation can cause insulation failure at very high voltage levels. The reasons of these problems are travelling waves which is generated during switching operations in a gas-insulated substation (GIS). Calculation of Very Fast Transient Overvoltage has been carried out using MATLAB7.8 for various switching.*

**Keywords**—disconnect or, High voltage level, MAT LAB, Switching, Switching operations, Travelling Very Fast Transient over voltages, Wavelet transform,

### I. INTRODUCTION

Very Fast Transient Over voltages (VFTOs) generated by switching operations. This type of overvoltages is dangerous for the transformer insulation due to a short rise time, which can cause non-linear voltage distribution along transformer windings. In some special cases, the turn-to-turn voltage can rise near the transformer basic insulation level [1]. These problems can either lead to direct break down or initiation of partial discharge which deteriorate the insulation. After a short time this can result in an insulation breakdown. These over voltages occur inside the winding and are difficult to measure and detect. Electromagnetic transients may appear with a wide range of frequencies that vary from several Hz to several hundreds of MHz transients and faster electromagnetic transients. The latter type of transients can occur for a shorter duration ranging from microseconds to several cycles. Frequency ranges are classified into groups for the ease of developing models accurate enough due to frequency behavior of power components. An accurate mathematical representation of each power component can generally be developed for a specific frequency range (CIGRE, 1990). One of the reasons of generated VFTOs is re-strikes and pre-strikes during opening or closing of switching devices. Very Fast Transients (VFT), also known as Very Fast Front Transients, belong to the highest frequency range of transients in power systems. According to the classification proposed by the CIGRE Working Group 33-02, VFT may vary from 100 kHz up to 50 MHz (1990). According to IEC 71-1, the shape of a very fast transient over voltage is “usually unidirectional with time to peak < 0.1 ms, total duration < 3 ms, and with superimposed oscillations at frequency 30 kHz < f < 100 MHz” (1993). The VFTOs in transformer windings have always been troublesome therefore it is important to analyze the wave both in time domain and frequency domain, therefore the wavelet transform is implemented. There are several works on VFTOs but this method is efficient and can be used to compute the effect of VFTOs on transformer.

In this paper a 132KV transformer is designed using Mat lab software of version 7.8, the VFTOs generated by switching conditions are calculated and are analyzed by wavelet transform and the result is tabulated and discussed.

Dis-connector Switch (DS) operation typically involves slow moving contacts which results in numerous discharges during operation .For example, a floating section of switchgear between a disconnect switch and an open breaker (load side may be disconnected from an energized Gas insulated system (supply side). For capacitive currents below—1 amp, are-strike occurs every time the voltage between the connects exceeds the dielectric strength of the gaseous medium between them. Each re-strike generates a spark, which equalizes the potentials between the switch **contacts. Following spark extinction, the supply and load side potentials will deviate according to the AC supply** voltage variation and the discharge characteristics of the load side respectively. Another spark will result when the voltage across the electrode gap dependent breakdown voltage UB and the potential difference of the load and supply side U. Each Dis-connector Switch (DS) operation generates a large number of ignitions between the moving contacts. The number of ignitions depends on the speed of the contacts. The largest and steepest surge voltages are generated only by those breakdowns at the largest contact gap

Dis-connector Switch (DS) operation typically involves slow moving contacts which results in numerous discharges during operation .For example, a floating section of switchgear between a disconnect switch and an open breaker (load side may be disconnected from an energized Gas insulated system (supply side). For capacitive currents below—1 amp, are-strike occurs every time the voltage between the connects exceeds the dielectric strength of the gaseous medium between them. Each re-strike generates a spark, which equalizes the potentials between the switch contacts. Following spark extinction, the supply and load side potentials will deviate according to the AC supply voltage variation and the discharge characteristics of the load side respectively. Another spark will result when the voltage across the electrode gap dependent breakdown voltage and the potential difference of the load and supply side. Each Disconnect or Switch (DS) operation generates a large number of ignitions between the moving contacts. The number of ignitions depends on the speed of the contacts. The largest and steepest surge voltages are generated only by those breakdowns at the largest contact gap.

## II. WAVELET TRANSFORM

A wavelet is a waveform of effectively limited duration that has an average value of zero. The driving force behind wavelet transforms (WTs) is to overcome the disadvantages embedded in short time Fourier transform (STFT), which provides constant resolution for all frequencies since it uses the same window for the analysis of the inspected signal  $x(t)$ . On the contrary, WTs use multi-resolution, that is, they use different window functions to analyze different frequency bands of the signal  $x(t)$ . Different window functions  $\psi(s,b,t)$ ; which are also called son wavelets, can be generated by dilation or compression of a mother wavelet  $\psi(t)$ , at different time frame. A scale is the inverse of its corresponding frequency. WTs can be categorized as discrete WTs or continuous WTs. For vibration-based fault diagnosis, usually continuous WTs are employed. A continuous type of wavelet transform (CWT) that is applied to the signal  $x(t)$  can be defined as,

$$w(a,b) = \frac{1}{\sqrt{a}} \int_{-\infty}^{\infty} f(t) \psi\left(\frac{t-b}{a}\right) dt \tag{2.1}$$

Where

- a is the dilation factor,
- b is the translation factor and
- $\psi(t)$  is the mother wavelet.
- $1/\sqrt{a}$  is an energy normalization term that makes wavelets of different scale has the same amount of energy.

A continuous wavelet transform (CWT) is used to divide a continuous-time function into wavelets. Unlike Fourier transform, the continuous wavelet transform possesses the ability to construct a time-frequency representation of a signal that offers very good time and frequency localization. In mathematics, the continuous wavelet transform of a continuous, square-integrable function  $x(t)$  at a scale  $a > 0$  and translational value  $b \in \mathbb{R}$  is expressed by the following integral

$$X_w(a,b) = \frac{1}{\sqrt{|a|}} \int_{-\infty}^{\infty} x(t) \psi^*\left(\frac{t-b}{a}\right) dt \tag{2.2}$$

where  $\psi(t)$  is a continuous function in both the time domain and the frequency domain called the mother wavelet and \* represents operation of complex conjugate. The main purpose of the mother wavelet is to provide a source function to generate the daughter wavelets which are simply the translated and scaled versions of the mother wavelet. To recover the original signal  $x(t)$ , inverse continuous wavelet transform can be exploited.

$$x(t) = \int_0^\infty \int_{-\infty}^\infty \frac{1}{a^2} X_w(a, b) \frac{1}{\sqrt{|a|}} \tilde{\psi}\left(\frac{t-b}{a}\right) db da \tag{2.3}$$

$\tilde{\psi}(t)$  is the dual function of  $\psi(t)$ . And the dual function should satisfy

$$\int_0^\infty \int_{-\infty}^\infty \frac{1}{|a^3|} \psi\left(\frac{t_1-b}{a}\right) \tilde{\psi}\left(\frac{t-b}{a}\right) db da = \delta(t-t_1). \tag{2.4}$$

Sometimes,  $\tilde{\psi}(t) = C_\psi^{-1} \psi(t)$ , where

$$C_\psi = \frac{1}{2} \int_{-\infty}^{+\infty} \frac{|\hat{\psi}(\zeta)|^2}{|\zeta|} d\zeta \tag{2.5}$$

is called the admissibility constant and  $\hat{\psi}$  is the Fourier transform of  $\psi$ . For a successful inverse transform, the admissibility constant has to satisfy the admissibility condition:

$$0 < C_\psi < +\infty.$$

It is possible to show that the admissibility condition implies that  $\hat{\psi}(0) = 0$ , so that a wavelet must integrate to zero.

### III. MODEL DEVELOPMENT OF 132KV TRANSFORMER

Despite the advancement in electrical measurement techniques and equipment, quantifying the VFTO at such high frequencies remains challenging. Actual measurement in the GIS during planning stage is not practically possible. Designers must use numerical tools to calculate the VFTO associated with switching operations in a GIS. This informs the design decision process to achieve a more robust and reliable system with adequate insulation levels for all equipments used. The existing technical literature shows that with good modeling techniques and appropriate assumptions, numerical tools can provide reasonably accurate predictions of the VFTO magnitude and their rate of rise [1], [2], [3], [4], [5], [6], [7]. The simulation studies reported here was performed using MAT LAB software, version of 7.8. Switching events in a GIS generates transients with frequencies in the range of hundreds of kHz up to tens of MHz. These transients cannot be calculated if conventional techniques of modelling and simulation are used.

Coaxial conductors in gas insulated substations have higher specific capacitance to earth. GIS is also characterized by lower surge impedance and inductance as well as larger gradient of the electric field between pre-strike and re-strike arcs in SF6 under pressure. This causes very fast transients with surge fronts of very short durations. Due to the geometrical structure of GIS and its low surge impedance, travelling waves reflection at the GIS entrance could rapidly result in sizeable over voltages at any open end within the GIS (i.e. due to multiple reflections). A disconnect or is represented by a PI section comprises of two travelling wave models, two capacitors to ground and a capacitor across the breaking contacts as shown in fig 1. A circuit breaker is represented by a PI circuit with five travelling wave models and four capacitors. Decaying resistance ( $R_0 e^{-t/T}$ ) in series with a small resistance,  $r$  of  $0.5 \Omega$  to take care of the residual spark resistance [11].

$$R = R_0 e^{-t/T} + r \tag{3.1}$$

The value of  $R_0$  is taken as  $1 \times 10^6 \text{ M}\Omega$  and  $T$  as 1 ns. This gives a resistance whose value varies from very high value ( $\text{M}\Omega$ ) to a low value of  $0.5 \Omega$  within 30 ns.

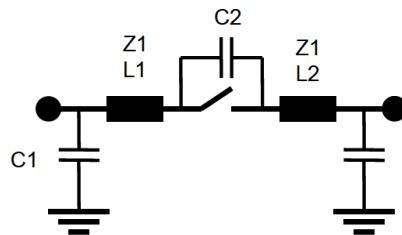
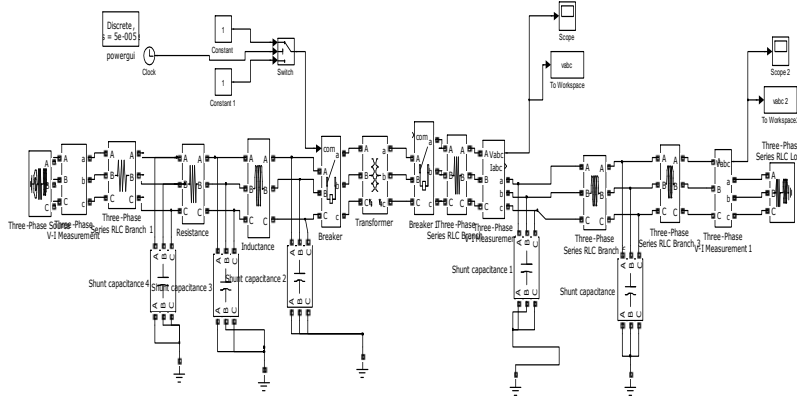

Fig.1 Disconnect

Where,  $Z_1 = 35 \Omega$ ,  $L_1 = 640 \text{ mm}$ ,  $L_2 = 450 \text{ mm}$ ,  $C_1 = 25 \text{ pF}$  and  $C_2 = 2.5 \text{ pF}$



Mat lab simulink Schematic Diagram of 132KV Power Transformer

#### IV. RESULTS AND DISCUSSIONS

A 132KV power transformer is modelled using mat lab software and the model of disconnector is used for switching conditions. The disconnector is provided at the transformer primary side with the operating times of 4/60 to 10/60 micro seconds. The conventional result of three phase voltage when transformer is subjected to switching condition is shown in fig 4.1 and the result extracted by wavelet transform is shown in fig 4.2. Also individual phases of transformer are subjected to switching conditions and their resultant voltages are captured and shown in figs 4.3, 4.5 and 4.7. The continuous wavelet transform is applied to extract the results of phase A, phase B and phase c and are shown in fig 4.4, 4.6 and 4.8. From the results it can be observed that there is error in the conventional methods of evaluation of VFTOs and wavelet transform gives an accurate result of VFTOs. The values are calculated and are tabulated in the table 1 taking peak value of VFTOs and Rise time of the wave forms. To analyse the VFTOs db wavelet transform is used with the level of Db7. The 50 Hz frequency signal is generated at the sampling period of 0.0002 and scale of 69.19. Table 1 gives the result of conventional method. Table II gives the result extracted by the wavelet transform. The error between conventional and wavelet transform is evaluated as 2.66% in magnitude of VFTOs and 5.3% error in rise time. Hence it is concluded that the wavelet transform gives very accurate result and is more efficient.

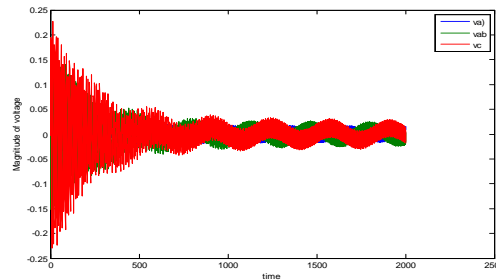

Fig.4.1 Three phase voltage waveform due to switching of three phase at transformer

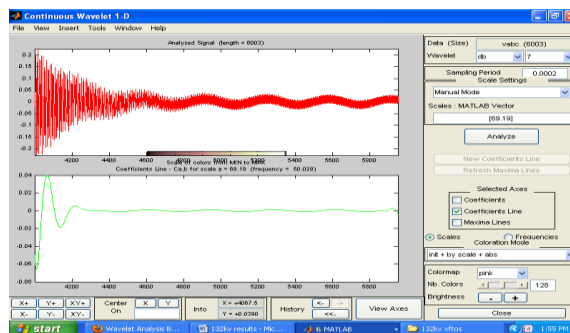

Fig.4.2 Wavelet result of Three phase voltage waveform due to switching of three phase at transformer

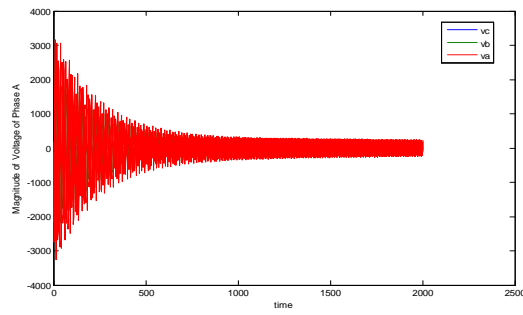

Fig.4.3 Voltage waveform due to switching in Phase A at transformer

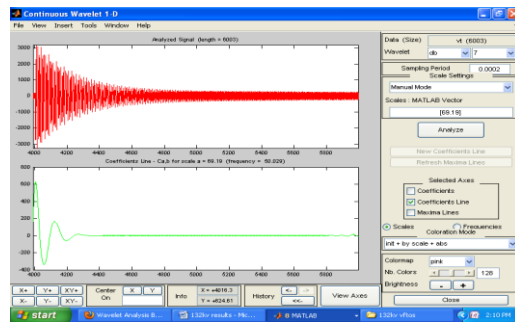

Fig.4.4 Wavelet result of Voltage due to switching in Phase A at transformer

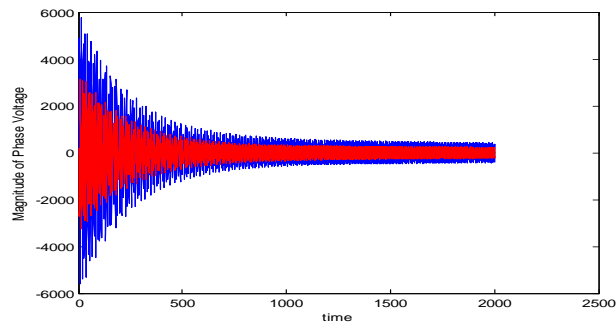

Fig.4.5 Voltage waveform due to switching in Phase B at Transformer

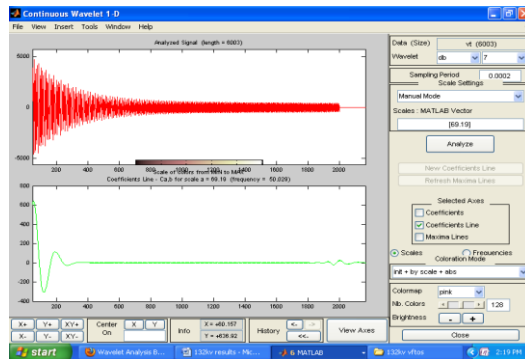

Fig.4.6 Wavelet result of Voltage waveform due to switching in Phase B at Transformer

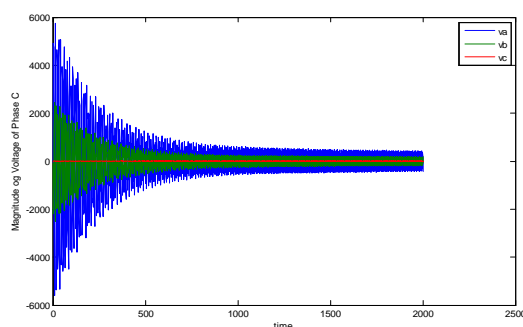

Fig.4.7 Voltage waveform due to switching in Phase C at Transformer

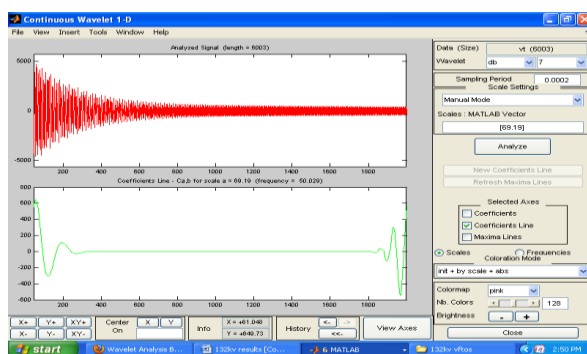

Fig.4.8 Wavelet result of Voltage waveform due to switching in Phase C at Transformer

Table I

Mode of Operation	Voltage Magnitude	Rise Time in (Nanoseconds )
Closing condition	2.45	75
Opening condition	1.35	64

Table II

Mode of Operation	Voltage Magnitude	Rise Time in (Nanoseconds )
Closing condition	2.19	79
Opening condition	1.56	54

## V. CONCLUSIONS

A model is developed for the prediction of the VFTO phenomena in the 132KV power transformer. The peak magnitude of Very fast transient over voltages generated during switching event have calculated for a 132kv GIS transformer for a particular switching operation. The VFTOs generated by switching operation are evaluated by both conventional and wavelet transform and by comparing both the methods it is observed that the error evaluated as 2.66% in magnitude of VFTOs and 5.3% in rise time .Hence it is concluded that wavelet transform is so accurate and can be used for practical applications for better performance.

## VI. ACKNOWLEDGEMENTS

The authors wish to gratefully acknowledge Smt.Dr.M.Suryakalavathi, Prof Dept of E.E.E, J.N.T.U.H, Hyderabad and her support for the completion of this work. The authors also wish to gratefully acknowledge Dr.B.Ravindranath Reddy for the support given in the completion of this research work.

## REFERENCES

- [1] U. Riechert et. Al, "Very Fast Transient Overvoltages during Switching of Bus-Charging Currents by 1100 kV Disconnectors", *CIGRE* 2010, A3\_107\_2010.
- [2] S. Ynabu et. al, "Estimation of Fast Transient Overvoltage in Gas- Insulated Substation.," *IEEE Trans. Power Delivery*, vol. 5, No. 4, Nov 1990.
- [3] Susumu Matsumura, Tohei Nitta, " Surge Propagation in Gas Insulated Substation", *IEEE Trans. Power Apparatus and Systems*, Vol. PAS-100, No.6 June 1981.
- [4] S.A. Boggs et. al, "The Modelling of Statistical Operating Parameters and the Computation of Operation-Induced Surge Waveforms for GIS Disconnectors", *Cigre*, 1984, Paper 13-15.
- [5] Z. Haznadar et. al, "More Accurate Modelling of Gas Insulated Substation Components in Digital Simulations of Very Fast Electromagnetic Transients.", *Transaction on Power Delivery*, Vol 7 No. 1 January 1992.
- [6] J. F. de Lima Filho et. al, "Tucuruí's 500 kV SF6 Gas-Insulated Substation Fast Transients – Analysis, Modeling and Field Test Comparisons", *International Conference on Power System Transients*, 1995.
- [7] P. Rohrbach, "550 kV GIS VFT Simulations as a Support for Transformer Design", *International Conference on Power System Transients*, 2001.
- [8] IEEE Fast Front Transients Working Group, "Modeling Guidelines for Fast Transients", *IEEE Trans on Power Delivery*, Vol 11, No 1, January 1996, p 493-506.
- [9] IEEE Very Fast Front Transients Working Group, "Modeling Guidelines for Very Fast Front Transients in Gas Insulated Substation".
- [10] V. Vinod Kumar, "Influence of Switching Conditions on the VFTO Magnitudes in a GIS", *IEEE Trans on Power Delivery*, Vol. 16, No. 4, October 2001.
- [11] H. W Dommel, "Transformer models in the simulation of electromagnetic transients", *Proc 5th Power Systems Computing Conference*, Cambridge, England, September 1-5, 1975.
- [12] A. Morched, B. Gustavsen, M. Tartibi, "A Universal Model for Accurate Calculation of Electromagnetic Transients on Overhead Lines and Underground Cables", *IEEE Transactions on Power Delivery*, Vol. 14, No. 3, pp. 1032-1038, July 1999.
- [13] *High-voltage switchgear and controlgear – Part 102 : Alternating current disconnectors and earthing switch*, BS EN 62271-102:2002.

## Biographies and Photographs



2) K.Prakasam, Born in 1973 April 20, his B.Tech degree from KSRM College of Engineering SV university in 1997 and M.Tech degree from SV university in the year 2004. He has specialized in Power Systems operation and Control Systems. his research interests include Simulation studies on Transients of different power system equipment. He has 16 years of experience. He is presently working as Prof .Prof and HOD of Dept of EEE, *Sri Sivani College of Engineering*, Srikakulam, Andhrapradesh, INDIA



1)D.Prabhavathi Born in 1976 august 27, her B.Tech degree from KSRM college of Engineering, kadapa , SV university, and M.Tech degree from SV University in the year 2004. She has specialized in Power Systems operation and control. Her research interests include Simulation studies on faults identification in UG cable of LT and HT. She has 12 years of experience. She is currently working as .Prof, dept of E.E.E *Sri Sivani College of Engineering*, Srikakulam, Andhrapradesh ,INDIA..



3) Dr. M. Surya Kalavathi, Born on 8th July 1966, Obtained her B.Tech degree from S.V. U. in 1988 and M.Tech from S.V.U. in the year 1992. Obtained her doctoral degree from JNTU, Hyderabad and Post Doctoral from CMU, USA. She is presently working as Professor (EEE) in JNTUH College of Engineering, Kukatpally, Hyderabad. Published 16 Research Papers and presently guiding many Ph.D. Scholars. She has specialized in Power Systems, High Voltage Engineering and Control Systems. Her research interests include Simulation studies on Transients of different power system equipment. She has 18 years of experience. She has invited for various lectures.



4) Bhumanapally.Ravindranth Reddy, Born on 3rd September, 1969. Got his B.Tech in Electrical & Electronics Engineering from the J.N.T.U. College of Engg., Anantapur in the year 1991. Completed his M.Tech in Energy Systems in IPGSR of J.N.T.University Hyderabad in the year 1997. Obtained his doctoral degree from JNTU, INDIA