

Power Quality Improvement Using Ac To Ac PWM Converter for Distribution Line

Shalini Bajpai

Jabalpur Engineering Collage Jabalpur MadhyaPradesh

ABSTRACT:

In this paper, a new voltage sag compensator for critical loads in electrical distribution system discussed. The proposed scheme employs a Pulsewidth modulation ac-ac convertor along with an auto transformer. During a disturbance such as voltage sag, the proposed scheme supplies the missing voltage and helps in maintaining rated voltage at the terminals of the critical load. Under normal condition the approach works in bypass mode and delivering utility power directly to load. A four step switching technique to drive the ac-ac convertor is employed to realize snubberless operation. A design is presented for 440v, 50 hz, system.

KEYWORDS:- Power Quality, Voltage Sag, PWM Ac-Ac Converter

I. INTRODUCTION: POWER QUALITY

POWER QUALITY is a term that mean different to different people. Institute of Electrical and electrical engineers (IEEE) standard IEEE 1100 defines power quality “as the concept of powering and grounding sensitive electronic equipment in a manner suitable for the equipment”. In a simpler words PQ is a set of electrical boundaries that allows a part of equipment to work in a intended manner without loss of performance or life expectancy.

In recent years power engineers are increasingly concerned over PQ due to following reasons:

1.1.REASONS FOR INCREASED CONCERN REGARDING POWER QUALITY

The most responsible reason is the newer-generation load equipment with microprocessor-based controls and power electronic devices such loads are more sensitive to power quality variations than was equipment used in the past. The another reason is the increased use of power electronics devices such as electrical drives ,fact devices, static relays etc due to the increased emphasis on improving overall power system efficiency . This is resulting in increasing harmonic levels on power systems and has many people concerned about the future impact on system capabilities. Increased awareness of power quality issues among the end users. Most of the systems are now interconnected in a network. Hence the processes are integrated in which the failure of any component can results into important consequences. The globalization of industries has increased the awareness about deficiencies in power quality around the world. The economic value of power quality is also one important reason for its increased concern. There is a big money associated with these power quality disturbances. Many efforts have been taken by the utilities to meet the consumer’s PQ requirements. Hence FACT devices and various other custom power devices are introduced in the electrical system to improve the PQ of the electrical power.

1.2.TYPES OF POWER QUALITY PROBLEMS

Voltage sag (or dip)

It is a dip of .1 to .9 p.u. in rms voltage or current at the power frequency, for interval of 0,5 cycle to 1 minute.

Causes: Whenever a load end draws a heavy current suddenly. That’s why it is associated with faults on the transmission or distribution network, faults in consumer’s installation , sudden connection of heavy loads and start-up of large motors.

Consequences: Malfunction of microprocessor-based control systems (PCs, PLCs, ASDs, etc), that may cause false tripping of contactors and electromechanical relays. Maloperation of electric rotating machines.

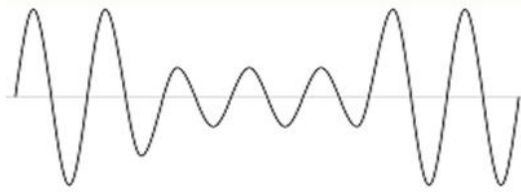

Fig.1-Voltage sag

II. VERY SHORT INTERRUPTIONS

It is a total interruption or decrease of supply voltage or load current to less than .1 p.u. for few milliseconds to one or two seconds.

Causes: It occurs due to failure of protecting devices, insulation failure, control malfunction. Also due to delayed reclosing of the protecting devices.

Consequences: False tripping of protection devices, loss of information results in malfunction of data processing equipment. Sensitive equipment stops working.

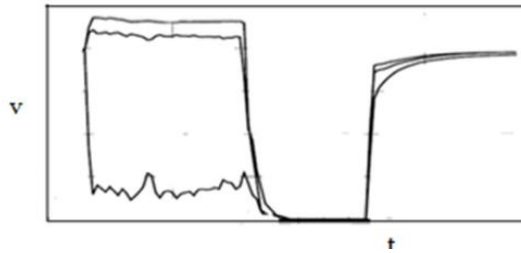

Fig.2- Very short interruptions

III. LONG INTERRUPTIONS

Total interruption of electrical supply for duration greater than 1 to 2 seconds

Causes: Equipment failure in the power system network, storms and objects (trees, cars, etc) striking lines or poles, fire, human error, bad coordination or failure of protection devices.

Consequences: Stoppage of all equipment.

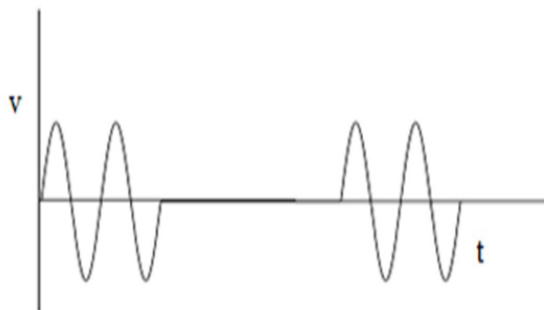

Fig.3- Long interruptions

IV. VOLTAGE SPIKE

It is the very fast variation of the voltage for durations from a several microseconds to few milliseconds. These variations may reach thousands of volts, even in low voltage.

Causes: Lightning which is a natural cause, switching of lines or power factor correction capacitors, sudden removal of heavy loads.

Consequences: Damage of components (particularly electronic components) and of insulation materials, data processing errors, electromagnetic interference or information loss.



Fig.4- Voltage Spike

V. VOLTAGE SWELL

Momentary increase of the voltage, at the power frequency, outside the normal tolerances, with duration of more than one cycle and typically less than a few seconds.

Causes: Start/stop of heavy loads, badly dimensioned power sources, badly regulated transformers (mainly during off-peak hours).

Consequences: Data loss, flickering of lighting and screens, stoppage or damage of sensitive equipment, if the voltage values are too high.

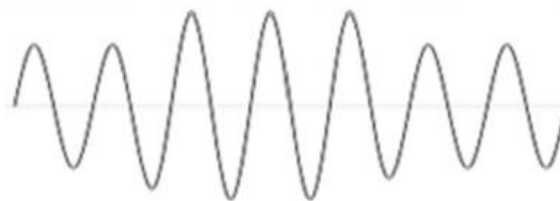

Fig.5- Voltage swell

VI. HARMONIC DISTORTION

These are periodically distorted voltage or current waveform. The waveform corresponds to the sum of different sine-waves with different magnitude and phase, having frequencies that are multiples of power-system frequency.

Causes: Arc furnances electric machines working above the magnetic saturation, welding machines, rectifiers, and DC brush motors. All non-linear loads, such as power electronics equipment including ASDs, switched mode power supplies, high efficiency lighting, data processing equipments.

Consequences: Probability of occurrence severe resonance increases, neutral overloading in 3-phase systems, overheating of all cables and equipment, loss of efficiency in electric machines, electromagnetic interference with communication systems, errors in measures when using average reading meters, nuisance tripping of thermal protections, can induce visual flicker in arc lighting.

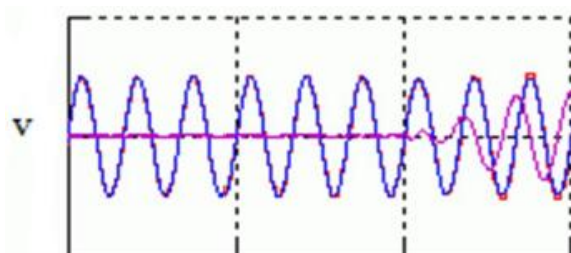

Fig.-6 Harmonic distortion

VII. VOLTAGE FLUCTUATION

It is a series of random voltage variations or systematic variations of voltage envelop but the variation does not exceeds the voltage ranges of 0.9 to 1.1 p.u. . Oscillation of voltage value, amplitude modulated by a signal with frequency of 0 to 30 Hz.

Causes: Frequent start/stop of electric motors (for instance elevators), oscillating loads, arc furnaces

Consequences: . The most perceptible consequence is the flickering of lighting and screens, giving the impression of unsteadiness of visual perception and the rest effects are similar to undervoltages.

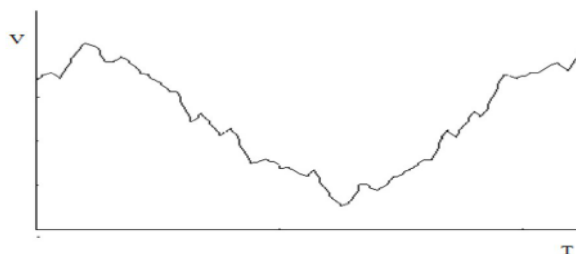

Fig.-7 Voltage fluctuation

VIII. NOISE

It is the Superimposing of high frequency unwanted signals on the waveform of the power-system frequency.

Causes: Electromagnetic interferences provoked by microwaves, television diffusion, and radiation due to welding machines, arc furnaces, and electronic equipment. Improper grounding may also be a cause.

Consequences: Disturbances on sensitive electronic equipment, usually not destructive. May cause some data related errors .

IX. VOLTAGE UNBALANCE

A maximum voltage variation in a three-phase system in which the three voltage magnitudes or the phase angle differences between them are not equal.

Causes:, Incorrect distribution of all single-phase loads by the three phases of the system (this may be also due to a fault). Large single-phase loads (induction furnaces, traction loads)

Consequences: It mostly affects three-phase induction machines. Unbalanced systems imply the existence of a negative sequence that is harmful to all three phase loads.

It has found that among all the PQ issues voltage sag and swell are the most occurring problems at the distribution end [1]-[2]-[3], as shown in fig.8-

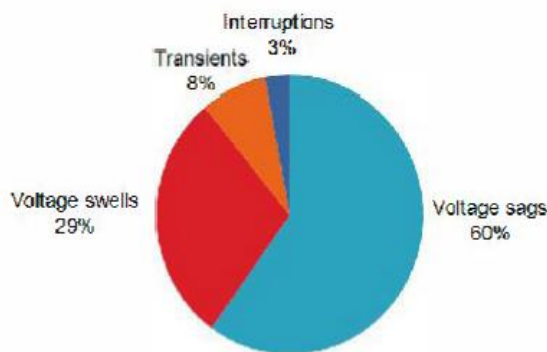

Fig.-8 Showing the occurring percentage of various PQ issues.

From fig.8 we can see that the voltage sag swell issues cover almost 89% of the graph area. That means they are the most responsible issues for decreasing power quality.

Proposed system configuration

The proposed device for mitigating voltage sag and swell in the system consists of a PWM switched power electronic device connected to an autotransformer in series with the load.

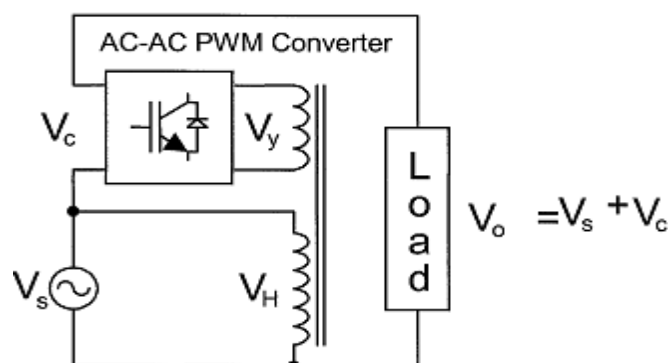

Fig. 9 shows the single phase circuit configuration of the mitigating device and the control circuit logic used in the system. It consists of a single PWM insulated gate bipolar transistor (IGBT) switch in a bridge configuration, a thyristor bypass switch, an autotransformer, and voltage controller.

PRINCIPLE OF OPERATION

To maintain the load voltage constant an IGBT is used as power electronic device to inject the error voltage into the line. Four power diodes (D1 to D4) connected to IGBT switch (SW) controls the direction of power flow and connected in ac voltage controller configuration with a suitable control circuit maintains constant rms load voltage. In this scheme sinusoidal PWM pulse technique is used. RMS value of the load voltage V_L is calculated and compared with the reference rms voltage V_{ref} . During normal condition the power flow is through the anti parallel thyristors. Output filters containing a main capacitor filter and a notch filter are used at the output side to filter out the switching noise and reduce harmonics. During this normal condition, $V_L = V_{ref}$ and the error voltage V_{err} is zero. The gate pulses are blocked to IGBT. Due to sudden increase or decrease in the load or due to faults voltage sag or swell occurs. The supply voltage V_S and hence V_L decreases. When the sensing circuit detects an error voltage V_{err} greater than 10% of the normal voltage the voltage controller acts immediately to switch off the thyristors. Voltage V_{err} applied to the pi controller gives the phase angle δ . The phase angle δ is dependent on the percentage of disturbance and hence controls the magnitude of $V_{control}$. This control voltage is then compared with the triangular voltage V_{tri} to generate the PWM pulses V_G which are applied to the IGBT to regulate the output voltage. Hence the IGBT switch operates only during voltage sag or swells condition and regulates the output voltage according to the PWM duty-cycle. To suppress the over voltage when the switches are turned off, RC snubber circuits are connected across the IGBT and thyristor.

SIMULATION ANALYSIS AND RESULTS

Simulation analysis is performed on a three-phase, 115/11 kV, 100 MVA, 50 Hz system to study the performance of the PWM switched autotransformer in mitigating the voltage sag and swell disturbances. The MATLAB/SIMULINK model of the system used for analysis is shown. An RL load is considered as a sensitive load, which is to be supplied at constant voltage. Tab. 1 shows the system parameter specifications used for simulation. Under normal condition, the power flow is through the antiparallel SCRs and the gate pulses are inhibited to IGBT. The load voltage and current are same as supply voltage and current. When a disturbance occurs, an error voltage which is the difference between the reference rms voltage and the load rms voltage is generated.

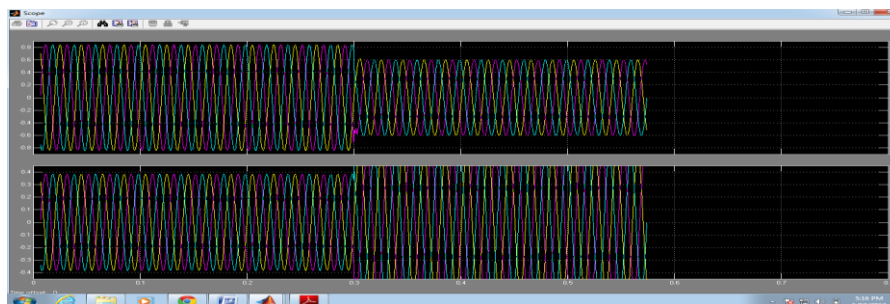

The PI controller thus gives the angle ω . Control voltage at fundamental frequency (50 Hz) is generated and compared with the carrier frequency triangular wave of carrier frequency 1.5 kHz. The PWM pulses now drive the IGBT switch. The simulation modeling of PWM switched autotransformer used as mitigating device along with its control circuit is shown. The autotransformer rating in each phase is 6.35/6.35 kV (as line voltage is 11 kV) with 1:1 turns ratio. The effective voltage available at the primary of autotransformer is such that the load voltage is maintained at desired rms value (6.35 kV or 1 pu).

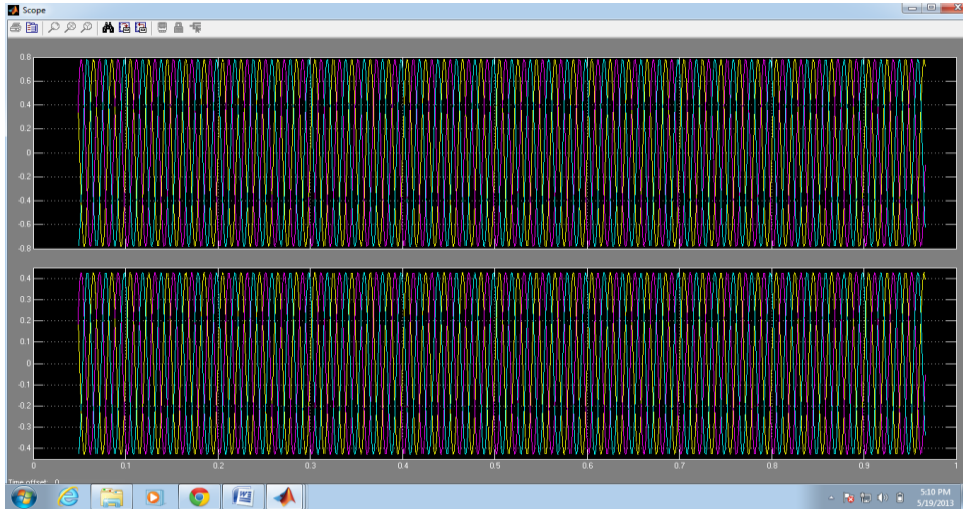

Voltage sag is created during the simulation by sudden application of heavy load of $P=10\text{MW}$ and $Q=50\text{Mvar}$ for a period of 0.1 sec (5 cycles) from $t_1 = 0.1$ sec to $t_2 = 0.2$ sec. Shows the simulation waveforms of the load voltage for voltage sag of 27%.

X. CONCLUSION

A new voltage sag compensator based on PWM switched autotransformer has been presented in this paper. Control circuit based on rms voltage reference is discussed. The proposed technique could identify the disturbance and capable of mitigating the disturbance by maintaining the load voltage at desired magnitude within limits. The proposed technique is simple and only one IGBT switch per phase is required. Hence the system is more simple and economical compared to commonly used DVR or STATCOM. Simulation analysis is performed for 27% voltage sag for three phase system and simulation results verify that the proposed device is effective in compensating the voltage sag disturbances.

REFERENCES

- [1] IEEE Recommended Practice for Emergency and Standby Power Systems for Industrial and Commercial Applications, vol. 445. The IEEE Standards Association, 1995.
- [2] R. Arnold. Solutions to the power quality problem. *Power Engineering Journal*, 2001, 65–73.
- [3] R. Cao, J. Zhao, et al. Series power quality compensator for voltage sags, swells, harmonics and unbalance. *IEEE/PES Transmission and Distribution Conference and Exposition*, 2001, 1(28): 543–547.
- [4] J. Chen, S. Song, Z. Wang. Analysis and implement of thyristor-based statcom. in: *International Conference on Power System Technology*, 2006, 1–5.
- [5] D. Lee, T. Habetler, et al. A voltage sag supporter utilizing a pwm-switched autotransformer. *IEEE Transactions on Power Electronics*, 2007, 22(2): 626–635.
- [6] C. Fitzer, M. Barnes, P. Green. Voltage sag detection technique for a dynamic voltage restorer. *IEEE Transportation Industry Applications*, 2004, 40(1): 203–212.
- [7] H. Masid, N. Moriun. Design of a prototype d-statcom for voltage sag mitigation. in: *Proceedings of the 2004 National Power and Energy Conf, Kuallampur, Malaysia*, 2004, 61–66.
- [8] M. McGranaghan, D. Mueller, M. Samotyj. Voltage sags in industrial systems. *IEEE Transactions on Industry Applications*, 1993, 29(2): 397–403.
- [9] G. Reed, M. Takeda, I. Iyoda. Improved power quality solutions using advanced solid-state switching and static compensation technologies. in: *IEEE Power Engineering Society 1999 Winter Meeting*, vol. 2, New York, USA, 1999, 1132–1137.
- [10] B. Singh, A. Adhya, et al. Analysis and implement of thyristor-based statcom for small isolated alternator feeding distribution system. *International Conference on Power Electronics and Drive Systems*, 2006, 1: 274–279.
- [11] G. Taylor. Power quality hardware solutions for distribution systems: Custom power. in: *IEE North Eastern Centre Power Section Symposium*, Durham, UK, 1995, 11/1–11/9.